

CAD FILE:

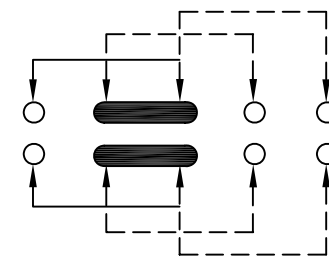

SCHEMATIC (SHORTING)

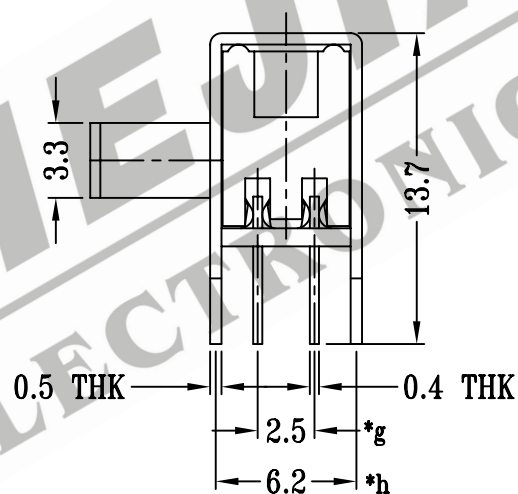
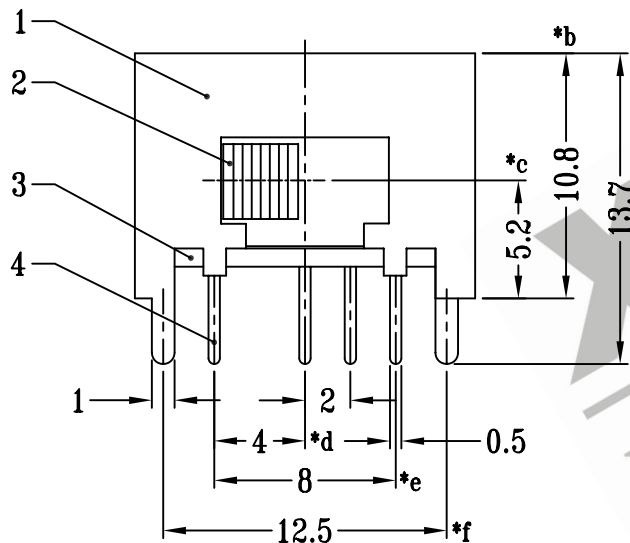
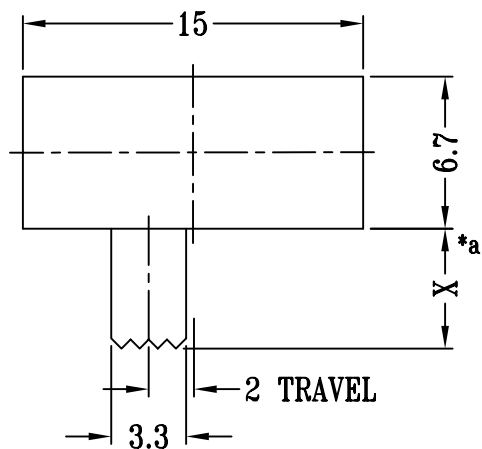
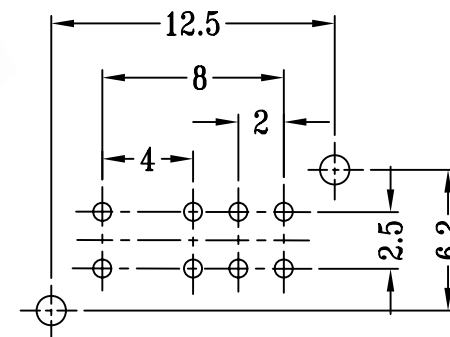

P.C.B LAYOUT

注:带"*"表示关键尺寸(8个)

NO.	PARTS	MATERIALS	Q'TY	FINISH	TOLERANCE UNLESS SPECIFIED	SHENZHEN XIEJIA ELECTRONICS CO.,LTD.				
8						TITLE : HORIZONTAL SLIDE SWITCH	UNIT : mm	DRWG NO.: XJ-DR-SK23D13-00		
7	STEEL BALL	STEEL	1	NATURAL	WITHIN: 1.5±0.1mm			ISSUE	DATE	DESCRIPTIONS OF REVISION
6	SPRING	STEEL WIRE	1	NATURAL	OVER : 1.5±0.2mm	MODEL: SK-23D13	SCALE: 3:1	CHK'D	FANGYING	2007-6-5
5	CONTACT CLIP	PBS STRIP	2	Ag PLATED		ALL MATERIALS MUST BE COMPLIANT TO ROHS		APPD.	KANGXINAN	2007-6-5
4	TERMINAL	BRASS STRIP	8	Ag PLATED OVER Ni PLATED						
3	BASE	PHENOLIC RESIN	1	NATURAL						
2	KNOB	POM	1	BLACK						
1	FRAME	STEEL STRIP	1	Ni PLATED						